

RUD Special-Eyebolt



Safety instructions

This safety instruction/declaration has to be kept on file for the whole lifetime of the product and forwarded with the product.
Translation of the Original instructions



**RUD Ketten
Rieger & Dietz GmbH u. Co. KG**
73432 Aalen
Tel. +49 7361 504-1370
sling@rud.com
www.rud.com

RUD-Art.-Nr.: 7904927 - EN / V03 - 09.024

RS-Special

RUD-Special-Eyebolt - fixed -



EG-Konformitätserklärung

entsprechend der EG-Maschinenrichtlinie 2006/42/EG, Anhang II A und ihren Änderungen

Hersteller: **RUD Ketten
Rieger & Dietz GmbH u. Co. KG**
Friedensinsel
73432 Aalen

Hiermit erklären wir, dass die nachfolgend bezeichnete Maschine aufgrund ihrer Konzipierung und Bauart, sowie in der von uns in Verkehr gebrachten Ausführung, den grundlegenden Sicherheits- und Gesundheitsanforderungen der EG-Maschinenrichtlinie 2006/42/EG sowie den unten aufgeführten harmonisierten und nationalen Normen sowie technischen Spezifikationen entspricht.
Bei einer nicht mit uns abgestimmten Änderung der Maschine verliert diese Erklärung ihre Gültigkeit.

Produktbezeichnung: Ringschraube
RS

Folgende harmonisierten Normen wurden angewandt:
DIN EN 1677-1 : 2009-03 DIN EN ISO 12100 : 2011-03

Folgende nationalen Normen und technische Spezifikationen wurden außerdem angewandt:
DGUV-R 109-017 : 2020-12

Für die Zusammenstellung der Konformitätsdokumentation bevollmächtigte Person:
Michael Betzler, RUD Ketten, 73432 Aalen

Aalen, den 15.04.2021 Hermann Kolb, Bereichsleitung MA *Hermann Kolb*
Name, Funktion und Unterschrift Verantwortlicher



EC-Declaration of conformity

According to the EC-Machinery Directive 2006/42/EC, annex II A and amendments

Manufacturer: **RUD Ketten
Rieger & Dietz GmbH u. Co. KG**
Friedensinsel
73432 Aalen

We hereby declare that the equipment sold by us because of its design and construction, as mentioned below, corresponds to the appropriate, basic requirements of safety and health of the corresponding EC-Machinery Directive 2006/42/EC as well as to the below mentioned harmonized and national norms as well as technical specifications.
In case of any modification of the equipment, not being agreed upon with us, this declaration becomes invalid.

Product name: Eye bolt
RS

The following harmonized norms were applied:
DIN EN 1677-1 : 2009-03 DIN EN ISO 12100 : 2011-03

The following national norms and technical specifications were applied:
DGUV-R 109-017 : 2020-12

Authorized person for the configuration of the declaration documents:
Michael Betzler, RUD Ketten, 73432 Aalen

Aalen, den 15.04.2021 Hermann Kolb, Bereichsleitung MA *Hermann Kolb*
Name, function and signature of the responsible person

User instructions

- Reference should be made to German Standards accord. DGUV rules 109-017 or other country specific statutory regulations and inspections are to be carried out by competent persons only.
- Before installing and every use, inspect visually RUD lifting points, paying particular attention to any evidence of corrosion, wear and weld cracks and deformations.
- The material construction to which the lifting point will be attached should be of adequate strength to withstand forces during lifting without deformation. The German testing authority BG, recommends the following minimum for bolt lengths:

1	x	M in steel (minimum quality S235JR [1.0037])
1.25	x	M in cast iron
2	x	M in aluminium
2.5	x	M in aluminium/magnesium alloys

(M = diameter of RUD lifting point bolt, for ex. M 20)

When lifting light metals, nonferrous heavy metals and gray cast iron the thread has to be chosen in such a way that the working load limit of the thread corresponds to the requirements of the respective base material

- The lifting points must be positioned on the load in such a way that movement is avoided during lifting

For single leg lifts, the lifting point should be vertically above the centre of gravity of the load.



ATTENTION

These special eye bolts must solely be loaded in the perpendicular direction of the thread!

- Attention: Rotation during the transportation must be avoided!**

- A plane bolt-on surface must be guaranteed. Tapped holes must be machined deep enough so that the bearing surface of the eyebolt will be supported.

If used solely axial (with a lift beam or in single fall) the special eyebolt can be used without a full-faced support (compare pic. 4). The recommendation of the BG (Employer's mutual insurance association) for the minimum thread engagement must absolutely be observed!



ATTENTION

Make sure, that no transverse force will be applied to the special eye bolt (swinging is forbidden)!

- The lifting mean must be free moveable in the RUD-Eyebolt and must not bear the load edge. When connecting and disconnecting lifting means (sling chains) no pinches, shearings and impacts must occur. Damage of the lifting means caused by sharp edges must be avoided.

- Shock loading or vibrations can cause unintentional dismantling. Securing options: liquid thread locker such as Loctite (depending on the application, please pay attention to the manufacturer's instruction). In general secure all lifting points which are permanently installed, f.e. by using glue.

- Effects of temperature:

If the RUD-Eyebolts are to be used in temperatures ranging from 100°C upwards, the WLL has to be reduced accordingly:

- 40° up to 100°C no reduction
- 100° up to 200°C minus 15 %
- 200° up to 250°C minus 20 %
- 250° up to 350°C minus 25 %

Temperatures above 350°C are not permitted.

- RUD-Lifting points must not be used under chemical influences such as acids, alkaline solutions and vapours e.g. in pickling baths or hot dip galvanising plants.

- The places where the lifting points are fixed should be marked with colour.

- After installation, an annual inspection or if necessary even sooner must be carried out by a competent person to guarantee the lingering ability. This is becomes also effective after a damage or a special occurrence.

Inspection criteria concerning paragraphs 2 and 12:

- Observe correct torque moment
- The lifting point must be complete
- The working load limit and manufacturer's stamp should be clearly visible.
- Deformation of the component parts such as body and bolt.
- Mechanical damage, such as notches, cracks particularly in high stress areas.
- Wear should be no more than 10 % of cross sectional diameter.
- Strong of corrosion
- Function/damage at the bolt and/or thread

A non-adherence to this advice may result damages of persons and materials!

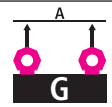
Method of lift		
Number of legs	1	1
Angle of inclination α	0°	0°
Metric type	Max. weight of load >G< in metric tons - bolted	
RS-Special M8	0.2 t	0.4 t
RS-Special M10	0.25 t	0.5 t
RS-Special M12	0.4 t	0.8 t
RS-Special M14	0.75 t	1.5 t
RS-Special M16	0.8 t	1.6 t
RS-Special M18	1.2 t	2.4 t
RS-Special M20	1.5 t	3.0 t
RS-Special M24	2.0 t	4.0 t
RS-Special M30	3.0 t	6.0 t
RS-Special M36	4.0 t	8.0 t
RS-Special M42	6.0 t	12.0 t

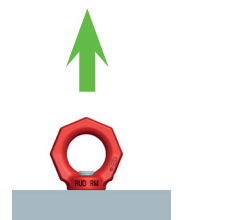

Pic. 1:
Only axial loading!

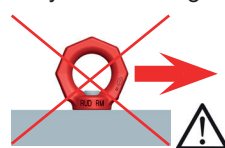

Pic. 2:
Forbidden loading

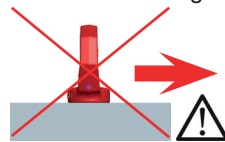

Pic. 3:
Forbidden loading



Pic. 4:
Only axial loading! No swinging!

Chart 1: WLL overview

Type	Tragfähigkeit WLL [kg]	A [mm]	B [mm]	C [mm]	D [mm]	E [mm]	F [mm]	M [mm]	Ref.-No.
RS-Special M8	200	16-989	11	10	25	25	24	M8	8600625
RS-Special M10	250	20-989	11	10	25	25	24	M10	8600625
RS-Special M12	400	24-988	13	12	30	30	27	M12	8600625
RS-Special M14	750	28-986	15	14	35	35	31	M14	8600625
RS-Special M16	800	32-986	15	14	35	35	31	M16	8600625
RS-Special M18	1200	36-983	17	16	40	40	35	M18	8600625
RS-Special M20	1500	40-983	17	16	40	40	35	M20	8600625
RS-Special M24	2000	48-978	21	20	50	50	44	M24	8600625
RS-Special M30	3000	60-973	26	24	60	60	56	M30	8600625
RS-Special M36	4000	72-960	43	38	90	100	88	M35	8600625
RS-Special M42	6000	84-960	43	38	90	100	88	M42	8600625

Chart 2: Dimension table

weight depends on the design

Subject to technical alterations

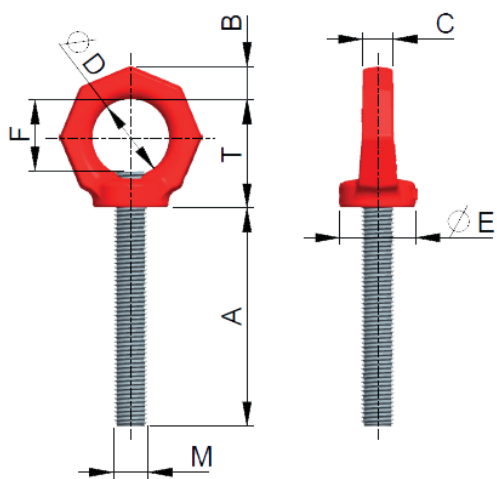

Pic. 5: Dimensioning