



ASPA Thread adapter for high tensile RUD lifting points



Safety instructions

This safety instruction has to be kept on file
for the whole lifetime of the product and forwarded with the product
TRANSLATION OF THE ORIGINAL INSTRUCTIONS



RUD-Art.-Nr.: 8503494-EN - V05 / 10.025

RUD Ketten
Rieger & Dietz GmbH u. Co. KG
73432 Aalen
Tel. +49 7361 504-5438
sling@rud.com
www.rud.com

ASPA Thread adapter for high tensile RUD lifting points

RUD

EG-Einbauklärung
entsprechend der EG-Maschinenrichtlinie 2006/42/EG, Anhang II B und ihren Änderungen

Hersteller: **RUD Ketten
Rieger & Dietz GmbH u. Co. KG**
Friedensinsel
73432 Aalen

Hiermit erklären wir, dass die nachfolgend bezeichnete unvollständige Maschine den grundlegenden Anforderungen der Maschinenrichtlinie 2006/42/EG (Anhang 1) entspricht. Die nachfolgend bezeichnete unvollständige Maschine darf, in der geleiteten Ausführung erst dann in Betrieb genommen werden, wenn festgestellt wurde, dass die Maschine, in die diese unvollständige Maschine eingebaut werden soll, den Anforderungen der EG-Maschinenrichtlinie 2006/42/EG entspricht.

Produktbezeichnung: Gewindeadapter
ASPA

Folgende harmonisierten Normen wurden angewandt:
DIN EN ISO 12100 : 2011-03

Folgende nationalen Normen und technische Spezifikationen wurden außerdem angewandt:
DGVV-R 109-017 : 2020-12

Die speziellen Unterlagen zur unvollständigen Maschine nach Anhang VII Teil B wurden erstellt und werden auf begründetes Verlangen in geeigneter Form übermittelt.

Für die Zusammenstellung der Konformitätsdokumentation bevollmächtigte Person:
Michael Betzler, RUD Ketten, 73432 Aalen

Aalen, den 01.06.2022 Hermann Kolb, Bereichsleitung MA
Name, Funktion und Unterschrift Verantwortlicher

RUD

EC-Mounting declaration
According to the EC-Machinery Directive 2006/42/EC, annex II B and amendments

Manufacturer: **RUD Ketten
Rieger & Dietz GmbH u. Co. KG**
Friedensinsel
73432 Aalen

We hereby declare that the following incomplete machines correspond to the basic requirements of the Machinery Directive 2006/42/EC (annex 1). The following incomplete machine, in the delivered machine, may only be put into operation when the machine in which the incomplete machine shall be assembled, has been tested according to the requirements of the EC-Machinery Directive 2006/42/EC.

Product name: Thread adaptor
ASPA

The following harmonized norms were applied:
DIN EN ISO 12100 : 2011-03

The following national norms and technical specifications were applied:
DGVV-R 109-017 : 2020-12

The special documents about the incomplete machine according to annex VII part B have been created and can be handed over in a suitable form on request.

Authorized person for the configuration of the declaration documents:
Michael Betzler, RUD Ketten, 73432 Aalen

Aalen, den 01.06.2022 Hermann Kolb, Bereichsleitung MA
Name, function and signature of the responsible person

RUD

Notice d'assemblage CE
Conformément à la directive machine 2006/42/CE, annexe II B et ses modifications

Fabricant: **RUD Ketten
Rieger & Dietz GmbH u. Co. KG**
Friedensinsel
73432 Aalen

Par la présente, nous déclarons que la machine incomplète indiquée ci-dessous correspond aux exigences de la directive machine en 2006/42/CE (annexe 1). La quasi-machine indiquée ci-dessous ne doit pas être mise en service avant que la machine finale dans la quelle elle doit être incorporée ait été déclarée conforme aux dispositions pertinentes de la directive 2006/42/CE.

Désignation du produit : Adaptateur de filetage
ASPA

En outre, les normes harmonisées suivantes ont été appliquées :
DIN EN ISO 12100 : 2011-03

Les normes et spécifications techniques nationales suivantes ont été appliquées :
DGVV-R 109-017 : 2020-12

Les informations pertinentes concernant la quasi-machine selon l'annexe VII partie B ont été produites et sont transmises à la suite d'une demande dûment motivée des autorités nationales.

Personne autorisée à constituer le dossier technique :
Michael Betzler, RUD Ketten, 73432 Aalen

Aalen, den 01.06.2022 Hermann Kolb, Bereichsleitung MA
Nom, fonction et signature du responsable

Assembly hints/User guide

1. Thread adapters should only be used as a reducer for already existing threads to allow the attachment of high tensile RUD lifting points. The thread adapters are marked with the inside and outside thread diameters.



ATTENTION

Never use DIN 580 or standard type eyebolts in combination with RUD thread adapters!

2. Thread adapters should only be used by competent persons being aware of DGUV-rules 109-017 (within Germany) or respective country specific legislation, regulations and/or standards.
3. Always check the thread adapter before use for torque, heavy corrosion, wear, deformation and damage etc.
4. The WLL of the adaptor is matched to the WLL of the RUD lifting point. Refer also to the user guide applicable to the lifting point.
5. Ensure the location of the installed thread adapter is suitable and that induced forces are accommodated by the work piece without deformation. The bolt-in depth of the thread adapter must be at least 1.2 times that of the outside thread diameter. With light metals, non ferrous heavy metals and grey cast iron, the thread arrangement must be calculated in such a way that the WLL corresponds with the capability of the work piece material.
6. Ensure a plane bolt-on surface (Diameter A) and provide a perpendicular threaded hole. Tapped blind holes must be deep enough to ensure the shoulder of the adapter sits flush with the bolt-on surface.
7. The thread adaptor provides spanner flats for a wrench, a groove for a hook spanner and a hole for an assembly pin. Care must be taken to ensure that the thread adapter is fully engaged and that the shoulder of the adapter accurately meets the bolt-on surface of the work piece. If the thread adapter is permanently installed on the work piece, RUD recommend applying the same torque as that stated for the RUD lifting point. To avoid misuse in combination with DIN 580 or standard type eyebolts RUD recommend to secure the high tensile RUD lifting point into the thread adapter with 'Loctite' or similar.
8. If used with shock loads or vibrations unintentional loosening can occur. RUD recommends correct torque plus 'Loctite' or similar (refer to user instructions of the manufacturer).

9. The temperature capability of the adapter also complies with the RUD high tensile lifting point in use.
10. RUD thread adapters and lifting points must not be used in combination with aggressive chemicals, acids or their fumes.
11. For better recognition, RUD recommends marking the location of the lifting point by using contrast colour.
12. Periodic inspection of the lifting point and adapter by a competent person is required. Inspect after installation and at intervals relative to usage, at least once a year. Especially in the event of damage and/or special incidents.

Inspection criteria for point 3 and 12:

- Correct torque
- Completeness, function and suitability of the thread adapter and the lifting point
- Clearly identifiable WLL and manufacturer identification
- Deformation of load bearing components, in particular the base material and bolt
- Mechanical damage, for example: notches, grooves, deformation, especially when located in a tensile stress zone
- Reduction of cross section caused by wear > 10 %
- Heavy corrosion
- Hairline cracks at load bearing parts
- Function and damage of bolt thread



ATTENTION

Non-observance of these details may lead to personal and/or material damage and exclusion of warranty.

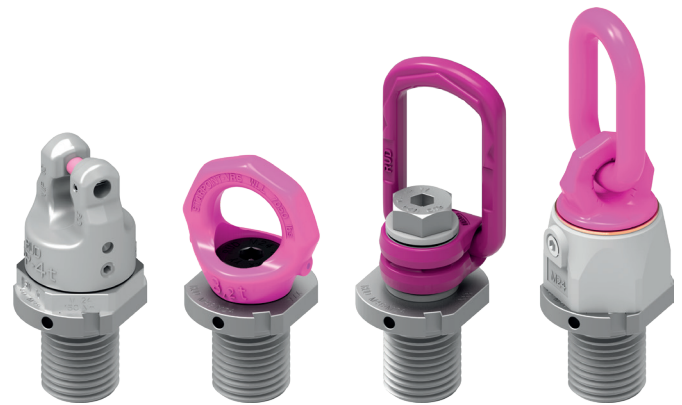

Assembly examples

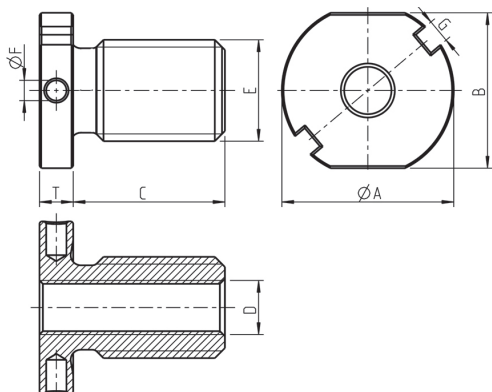

Adapter E x D	Part- No.	Weight (kg)	A	B	C	D	E	F	G	T
ASPA-M 16 x M 8	7994782	0.07	35	30	20	M8	M16	5	6	8
ASPA-M 20 x M 10	7995682	0.11	38	32	24	M10	M20	5	6	9
ASPA-M 24 x M 12	7993856	0.15	42	36	28	M12	M24	5	6	9
ASPA-M 30 x M 16	7993857	0.27	51	46	36	M16	M30	6	7	10
ASPA-M 36 x M 20	7993858	0.48	65	55	43	M20	M36	6	8	12
ASPA-M 42 x M 24	7995674	0.8	82	70	50	M24	M42	8	10	13
ASPA-M 48 x M 24	7995675	1.1	82	70	58	M24	M48	8	10	14
ASPA-M 56 x M 30	7995676	1.75	100	90	67	M30	M56	8	10	16
ASPA-M 64 x M 36	7995677	2.3	110	95	77	M36	M64	8	10	16
ASPA-M 72 x M 42	7904234	2.7	110	95	86	M42	M72	8	10	16
ASPA-M 80 x M 48	7900469	3.4	110	95	96	M48	M80	8	10	16
ASPA-M 90 x M 48										

Table 1

dimensions in mm



Translation of the original instruction manual

In case of doubts or misunderstandings, the German version of the document is decisive.