

Skip container-single suspension link

>IMEG<

+ Spare parts set

Assembly instructions

These assembly instructions has to be kept on file for the whole lifetime of the product and forwarded with the product.
TRANSLATION OF THE ORIGINAL ASSEMBLY INSTRUCTIONS
 These assembly instructions apply in addition to the operating instructions for RUD lifting chains (ICE-No. 7995555).



ICE-skip container-single suspension link
IMEG

Spare parts set
 7902648

Spare parts set
 7910986

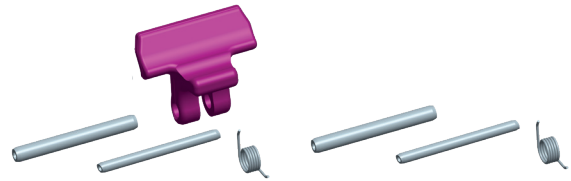

RUD Ketten
Rieger & Dietz GmbH u. Co. KG
 73432 Aalen
 Tel. +49 7361 504-5438
 sling@rud.com
 www.rud.com

RUD-Art.-Nr.: 7902661 - EN - V04 / 06.025



Simple test, management and documentation subject to mandatory testing operating resources, equipment and components.



EG-Einbauerklärung

entsprechend der EG-Maschinenrichtlinie 2006/42/EG, Anhang II B und ihren Änderungen

Hersteller: **RUD Ketten**
Rieger & Dietz GmbH u. Co. KG
 Friedensinsel
 73432 Aalen

Hiermit erklären wir, dass die nachfolgend bezeichnete unvollständige Maschine den grundlegenden Anforderungen der Maschinenrichtlinie 2006/42/EG (Anhang 1) entspricht. Die nachfolgend bezeichnete unvollständige Maschine darf, in der gelieferten Ausführung erst dann in Betrieb genommen werden, wenn festgestellt wurde, dass die Maschine, in die diese unvollständige Maschine eingebaut werden soll, den Anforderungen der EG-Maschinenrichtlinie 2006/42/EG entspricht.

Produktbezeichnung: Mulden-Einhängeglied
IMEG / VMEG

Folgende harmonisierten Normen wurden angewandt:
DIN EN 1677-1 : 2009-03 DIN EN ISO 12100 : 2011-03

Folgende nationalen Normen und technische Spezifikationen wurden außerdem angewandt:
DGVU-R 109-017 : 2020-12

Die speziellen Unterlagen zur unvollständigen Maschine nach Anhang VII Teil B wurden erstellt und werden auf begründetes Verlangen in geeigneter Form übermittelt.

Für die Zusammenstellung der Konformitätsdokumentation bevollmächtigte Person:
 Michael Betzler, RUD Ketten, 73432 Aalen

Aalen, den 01.06.2022 Hermann Kolb, Bereichsleitung MA 
 Name, Funktion und Unterschrift Verantwortlicher



EC-Mounting declaration

According to the EC-Machinery Directive 2006/42/EC, annex II B and amendments

Manufacturer: **RUD Ketten**
Rieger & Dietz GmbH u. Co. KG
 Friedensinsel
 73432 Aalen
 Germany

We hereby declare that the following incomplete machines correspond to the basic requirements of the Machinery Directive 2006/42/EC (annex 1). The following incomplete machine, in the delivered machine, may only be put into operation when the machine in which the incomplete machine shall be assembled, has been tested according to the requirements of the EC-Machinery Directive 2006/42/EC.

Product name: Dumper truck suspension-ring
IMEG / VMEG

The following harmonized norms were applied:
DIN EN 1677-1 : 2009-03 DIN EN ISO 12100 : 2011-03

The following national norms and technical specifications were applied:
DGVU-R 109-017 : 2020-12

The special documents about the incomplete machine according to annex VII part B have been created and can be handed over in a suitable form on request.

Authorized person for the configuration of the declaration documents:
 Michael Betzler, RUD Ketten, 73432 Aalen

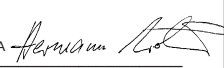
Aalen, den 01.06.2022 Hermann Kolb, Bereichsleitung MA 
 Name, function and signature of the responsible person



Before using, always read the skip container single suspension link assembly instructions carefully. Always ensure that you have understood all the contents. Failure to comply with the instructions can result in physical injury or material damage and will invalidate the warranty.

The supplied instructions apply to the following single suspension links for skip containers:

- **IMEG-ICE**-skip container single suspension link in ICE-pink /traffic purple (Quality Class 12, D1 Stamping)

The spare parts set (RUD-Article-No. 7902648/7910986) can be used for the following RUD-skip container single suspension link: IMEG-10 and IMEG-13.

The information regarding the IMEG spare parts set can be found in Section 5 *IMEG spare parts set*.

1 Safety instructions



WARNING

If sling and lashing systems are incorrectly assembled or damaged as well as incorrectly used, then this can result in physical injury and material damage in the event of a fall.

Always control all sling systems carefully prior to each use.

- Keep all body parts like fingers, hands, arms, etc. out of the hazardous area during the lifting operation.
- Wear safety glasses for the spring assembly of the spare part set. The spring may pop out of the hook. Risk of injury.
- Any technical modifications at the skip container single suspension links are prohibited.
- Keep persons out of the hazardous area.
- Detention under a floating load is forbidden.
- Take any extreme circumstances or shock loads into account when selecting the skip container single suspension link and the components to be utilized.
- Damaged or worn skip container single suspension links must no longer be used.
- The skip container single suspension links may only be used by authorized and trained people in adherence with DGUV Regulation 109-017 and according to the country-specific provisions and regulations outside Germany.

2 Intended use

The skip container single suspension links described here may only be used for lifting or transporting loads when the hooks are locked shut.

Keep in mind that the skip container single suspension link must be aligned in the direction of the tension. It must never be subjected to bending forces.

The IMEG-10 and IMEG 13 skip container single suspension links are designed and constructed for the lifting and the transport of skip containers according to DIN 30720-1 and DIN 30720-2.

Only utilize the skip container single suspension links with RUD chains.

Skip container single suspension may only be exclusively used for the purposes described here for lifting and/or transporting of loads.

3 Instructions for assembly and use

3.1 General information

- Temperature application suitability **ICE components (IMEG-10, IMEG-13)**:

The load-bearing capability of the ICE-skip container single suspension links must be reduced as follows when used above 200°C:

-60°C to 200°C	no reduction
200°C up to 250°C	minus 10%
250°C to 300°C	minus 40%
temperatures above 300°C are not permissible!	

- The skip container single suspension links must not be brought into contact with aggressive chemicals, acids or their vapors.
- The load-bearing capabilities of the components are dependent on the following variables:
 - Quality class of the component (*Fig. 1*)
 - Nominal size of the component
 - Existing load case

The permitted load-bearing capabilities can be found in the corresponding ICE-Operating instructions (or alternatively www.rud.de).

3.2 Assembly notes

Always pay attention to the correct arrangement of the chain to the component when assembling the skip container single suspension links. The quality class/rated thickness of the component is indicated by the marking/stamping in the component/bolt/chain and/or the color scheme:



NOTE

Always adhere to the quality classes when arranging the components:

- Only assemble the ICE-components (IMEG-10, IMEG-13) with connection bolts with D1-12- Stamping.

Mixing system parts of different quality classes / rated sizes is not permitted.

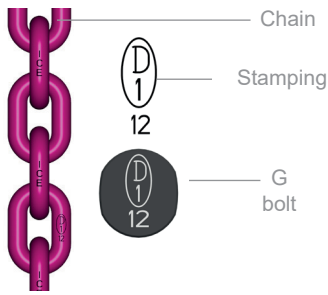

Fig.1: ICE-chain
Quality Class 12. | Stamping D1-12 | Oval bolt D1-12

The following applies in general:

- Fit the slotted spring clip for securing the connecting bolts into the fork head in such a way that slot of the spring clip is visible pointing forward.
- RUD G-bolts are distinctive:
 - Only utilize oval ICE-G bolts (Fig. 1) with ICE components
- The G-bolt must be assembled through the dowel pin and staged drill holes as inextricable in the component (Fig. 2).
- Only utilize the slotted spring clip once.
- Only utilize original RUD-spare parts.
- Finally check to ensure correct assembly (refer to Section 4 Inspection / Repair / Disposal).

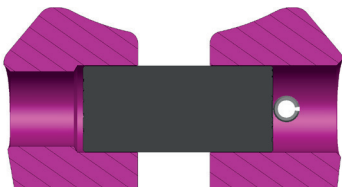

Fig. 2: G bolt assembly through locking pin and staged drill hole (left). One G bolt of the next smaller size will fall out.

Note for handling with skip container single suspension links IMEG-10 and IMEG 13:

The IMEG-10 and IMEG 13 skip container single suspension links are designed and constructed for the lifting and the transport of skip containers according to DIN 30720-1 and DIN 30720-2.

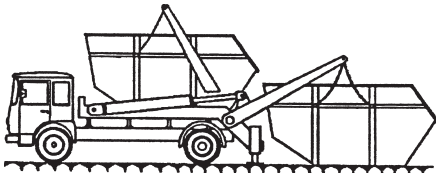

Fig. 3: Skip container application



ATTENTION

Parts of the body (fingers, hands, arms etc.) located in the interior space of skip container single suspension link can be crushed and injured during attaching and lifting procedures.

Keep all limbs out of the application area of the skip container single suspension links when attaching/lifting components.

Note for handling with skip container single suspension links IMEG-10 and IMEG 13

1. Open the securing flap (1) of the skip container single suspension link and hang it into the bitt. The securing flap closes automatically (Fig. 4). Flap must be closed behind the face of the bitt.

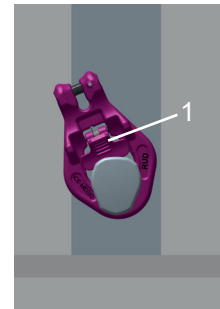

Fig. 4: IMEG hooked into bitt

- The inside contour is designed to avoid unintentional unhooking of the skip container single suspension link for skip containers according to DIN 30720-1 and DIN 30720-2. The skip container single suspension link must be assembled and locked on the skip container lugs according to Fig. 5 to provide securing.



NOTE

The skip container single suspension link must be able to be aligned in the direction of tension with diagonal tension (Fig. 5)

Fig. 5: Alignment of IMEG-10, IMEG 13 with diagonal tension

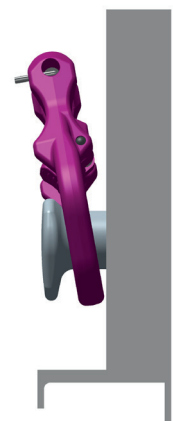

3.3 General information regarding use

- Control the skip container single suspension link before every loading to ensure that the G bolt securing has activated.
- Ensure that the force effect is executed in a straight line without any twists, buckling or kinks.

- Control the entire sling/lashing system at regular intervals and before every commissioning for the advanced suitability for use as a sling/lashing system against severe corrosion, wear, deformation etc. (refer to Section 4 Inspection / Repair / Disposal).



WARNING

If sling and lashing systems are incorrectly assembled or damaged as well as incorrectly used, then this can result in physical injury and material damage in the event of a fall. Always control all sling systems carefully prior to each use.

- RUD components have been designed as per DINEN 818 and DIN EN 1677 for a dynamic load of 20,000 load cycles.
 - Observe and be aware that multiple load cycles can occur during a lifting operation.
 - Observe the risk of product damage caused by high dynamical influences at high load cycle numbers.
 - BG/DGUV Germany's employer insurance association recommends: At high dynamical loading with a high number of load cycles (permanent use), the stress at WLL acc. to FEM class 1Bm (M3 acc. to DIN EN 818-7) must be reduced.
- Move away as far away as possible from the immediate hazard zone.
- Always supervise suspended loads.

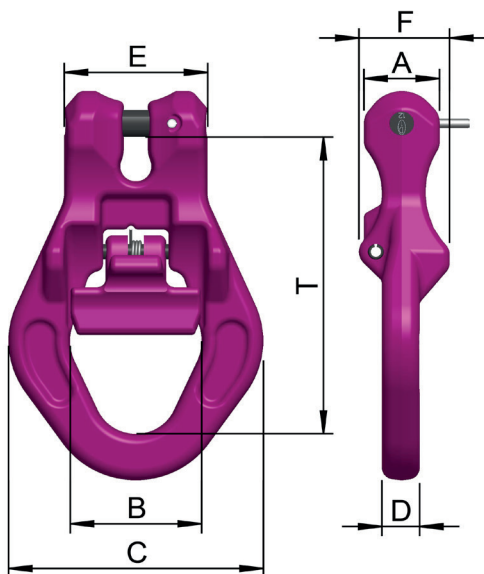

Fig. 6: IMEG-10 and IMEG-13 (magenta)

- Observe the operating instructions for RUD lifting chains and/or the appropriate load-bearing capability for the complete sling/lashing system (ICE Quality Class 12).

4 Inspection / Repair / Disposal

4.1 Hints for the regularly inspection

The operator has to determine and dictate the necessary inspection periods and the deadlines by a risk assessment (see sections 4.2 and 4.3).

The persisting appropriateness of the lifting point must be checked by a competent person (auditor) at least once per year.

Depending on the conditions of use e.g. frequent use, increased wear or corrosion, it may be necessary to carry out inspections at shorter intervals than once per year. A verification is also required following damage and after special events. The operator must specify the test cycles.

4.2 Inspection criteria for the regularly examination carried out by the operator

- Completeness of the skip container single suspension link
- Legibility of dimension markings and manufacturer markings
- Mechanical damage such as significant indentations, particularly in areas subject to tensile stress
- Cracks or other damage
- Deformation of the component
- The reset function of the securing flap must be ensured.

4.3 Additional inspection criteria for the competent person resp. auditor

- Reduction of cross section cause by wear of more than 10 %
- Strong corrosion
- Additional inspections may be necessary depending on the result of the risk assessment (e.g. incipient cracks at load bearing parts).



NOTE

The permitted load-bearing capabilities can be found in the corresponding ICE-Operating instructions (or alternatively www.rud.com).

	Designation	Chain	WLL [t]	A [mm]	B [mm]	C [mm]	D [mm]	E [mm]	F [mm]	T [mm]	Weight [kg/piece.]	Art. No.
ICE	IMEG-10	ICE-10	5.0	38	66	128	20	72	46	153	2.2	7901607
ICE	IMEG-13	ICE-13	8.0	38	66	128	20	72	46	147	2.2	8504471

Table 1: Measurement Table

subject to technical modifications

4.4 Hints for repair

- Repair work may only be executed by qualified specialists who can verify the necessary skills and training.
- Only utilize original RUD spare parts and record the completed repair/service work by entering them in the chain record card (the entire sling system) and/ or by using AYE-D.NET.

4.5 Disposal

Dispose of the discarded components / accessories or packaging in line with local regulations.

5 IMEG spare parts set



NOTE

The IMEG spare parts set may only be assembled by trained people (with the appropriate skills). Only utilize original - RUD-spare parts.

5.1 Contents of the IMEG/VMEG spare parts set

Contents of IMEG spare parts set 7902648	Contents of IMEG spare parts set 7910986	Figure
1x securing flap	--	
1x coiled spring	20x coiled spring	
1x slotted spring pin Ø8x70	20x slotted spring pin Ø8x70	
1x slotted spring pin Ø5x70	20x slotted spring pin Ø5x70	
1x assembly instructions	1x assembly instructions	

Table 2: Contents

5.2 Tools required

- 1x hammer
- 2x assembly aid (e.g. punch) (diameter approx. 8 mm (< 8.4 mm) and length > 70 mm)

5.3 IMEG assembly spare parts set

1. Only assemble the IMEG spare parts kit in matching RUD-skip container single suspension links (compare with Table 3):

Spare parts set RUD-Ref.-No.	Suitable for following RUD-skip container single suspension links
7902648/ 7910986	IMEG-10
	IMEG-13

Table 3: Arrangement

2. Insert the securing flap in the skip container single suspension link and align it with the drill holes.
3. Insert the installation aids in the drill holes on both sides.
Ensure that the assembly aids do not jam in the drill holes.

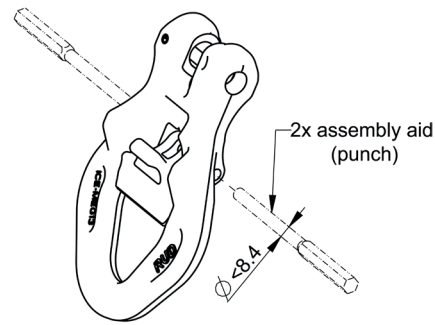

Fig. 7: Assembly aids

4. Flush assemble the assembly aids to the groove at the bottom of the securing flap.

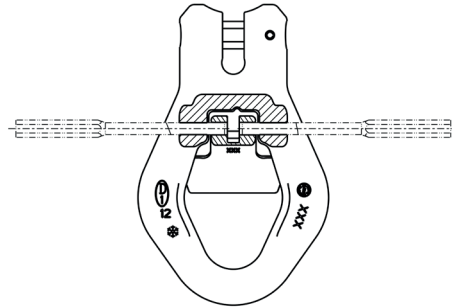

Fig. 8: Assembly aids

5. Spring assembly:



WARNING

The spring may unclip from the component! Risk of injury! Always wear safety glasses when assembling the springs.

Insert the coiled spring from above into the groove of the securing flap and align the spring in the drill hole.

During insertion, the spring will be pre-tensioned by contact with the components, this can lead to out unclipping/loosening of the spring.



NOTE

Make sure that, for a correct assembly, the longer spring shank is positioned on the single suspension link (the shorter spring shank points towards the securing flap, compare with Fig. 9/10).

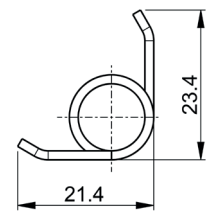

Fig. 9: Spring dimensions

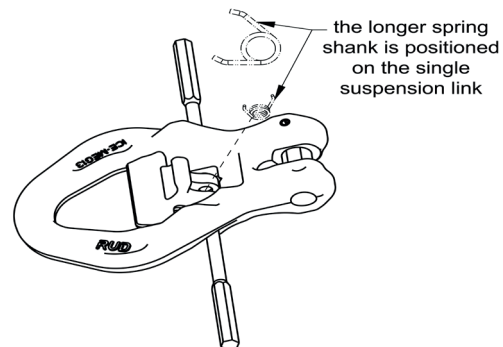

Fig. 10: Correct spring assembly

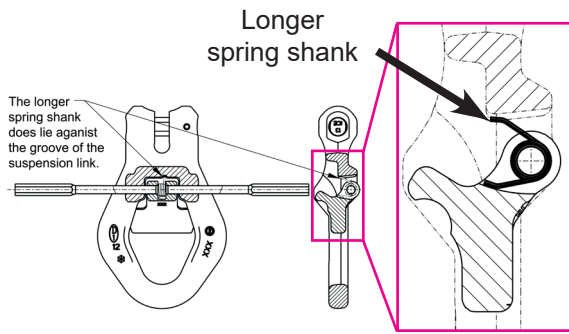

Fig. 11: Spring shank position

6. Now slide **one** (1) of the assembly aids through the spring into the drill hole in the opposite side. The other assembly aid (2) is pushed out as a result.

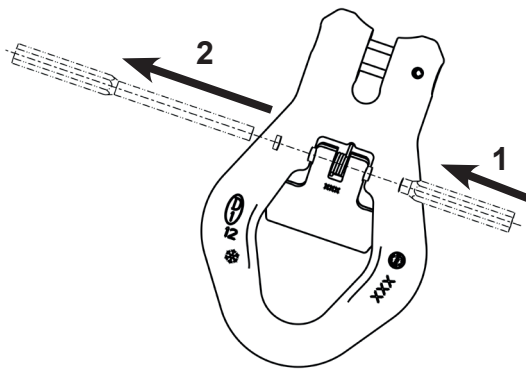

Fig. 12:

7. Assemble the slotted spring pin $\text{Ø}8 \times 70$ (3) with hammer blows (in the interior of the spring).



HINT

Make sure that position of split pin groove $\text{Ø}8 \times 70$ shows towards the suspension link. The groove of the split pin $\text{Ø}5 \times 70$ (step 8) must be staggered by 180° (into direction of clevis)

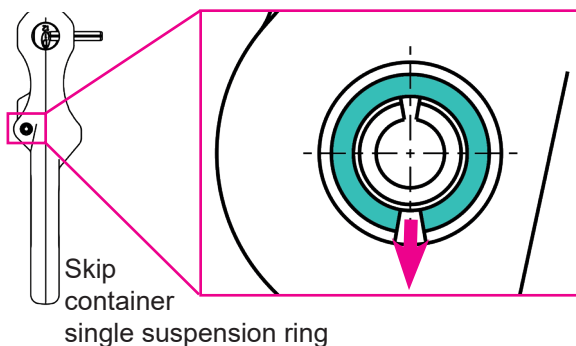

Fig. 13: Direction towards skip suspension ring

The assembly aid should always have constant contact with the slotted spring pin during hammering down. The second assembly aid (2) will therefore be driven out.

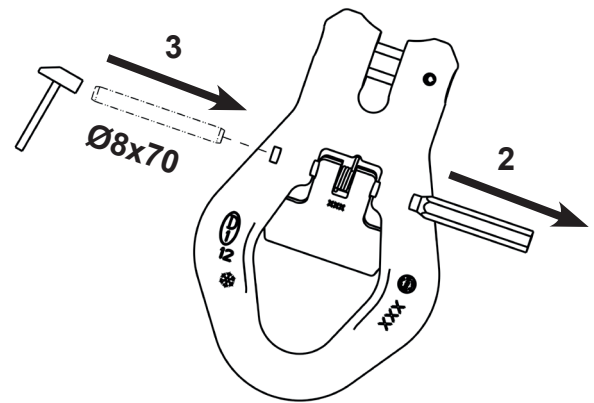

Fig. 14: Fixing of the spring by utilizing a slotted spring pin

8. Install split pin $\text{Ø}5 \times 70$ (4) with hammer centric into the inside of the slotted pin $\text{Ø}8 \times 70$ (at the inside of the spring). Avoid that the outer slotted pin $\text{Ø}8 \times 70$ will not be pounded out during installation by using a suitable bearing surface.



HINT

Hint Both slotted pins must be installed shifted to each other: Pay attention and make sure that the groove of the slotted pin $\text{Ø}5 \times 70$ is facing the clevis connection (groove must be displaced by 180° to the slotted pin $\text{Ø}8 \times 70$).

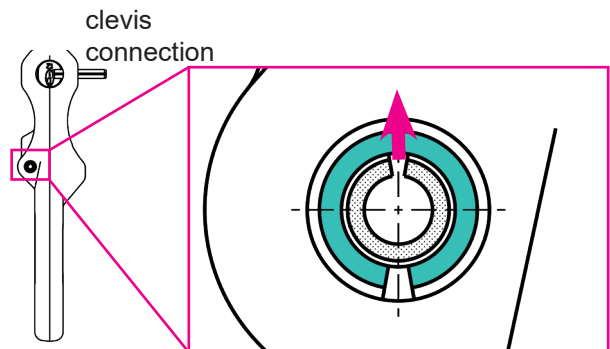

Fig. 15: Position

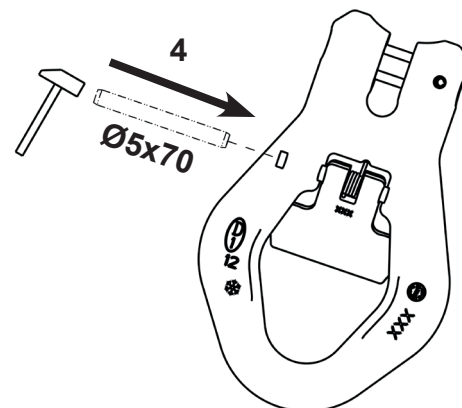

Fig. 16: Position

9. Always ensure that the slotted spring pin does not protrude beyond the drill hole end (slotted spring pin should be assembled as far as possible to the same possible depth on both drill hole ends).

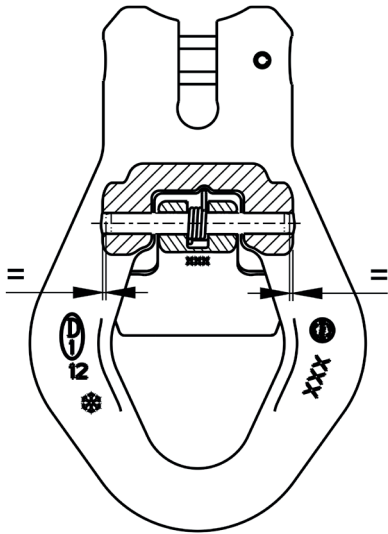

Fig. 17: Central position of the spring

10. Function Test:
Convince yourself that, when the spare parts set has been properly assembled, the securing flap can be opened and closed again by the spring force.