

# Lashing ring weldable

## > LRBS <



### Safety instructions

This safety instruction has to be kept on file for the whole lifetime of the product and forwarded with the product.

TRANSLATION OF THE ORIGINAL SAFETY INSTRUCTION

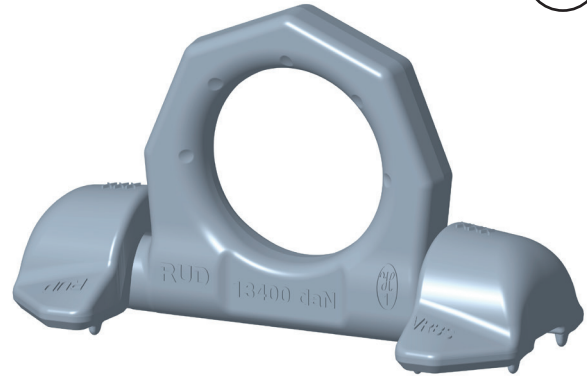

 **RUD**®

**RUD Ketten**  
**Rieger & Dietz GmbH u. Co. KG**  
73432 Aalen  
Tel. +49 7361 504-5438  
sling@rud.com  
www.rud.com

RUD-Art.-Nr.: 8603156-EN / V04 / 07.025

Lashing Ringbock schweißbar  
Lashing ring weldable

## > LRBS <

### Herstellererklärung

Hiermit erklären wir (unterstützt durch die Zertifizierung nach ISO 9001), dass die nachfolgend bezeichnete Ausrüstung aufgrund ihrer Konzipierung und Bauart, sowie der von uns in Verkehr gebrachten Ausführung, den einschlägigen grundlegenden Sicherheits- und Gesundheitsanforderungen der Europäischen Union entspricht. Bei einer nicht mit uns abgestimmten Änderung der Ausrüstung verliert diese Erklärung ihre Gültigkeit. Weiterhin verliert diese Erklärung ihre Gültigkeit, wenn die Ausrüstung nicht entsprechend den in der Betriebsanleitung aufgezeigten bestimmungsmäßigen Fällen eingesetzt wird.

Hinweis: Beim Zurrpunkt angewendete harmonisierte Normen DIN EN ISO 12100 T1 und T2 sowie in Anlehnung an EN 1677.

Bezeichnung der Ausrüstung:  
Zurrpunkt

Typ: Lashing Ringbock: LRBS

Herstellerzeichen: 

### Declaration of the manufacturer

We hereby declare (supported by ISO 9001 certification), that the following described equipment based on the concept and design as well as the by us manufactured type corresponds to the current valid Health- and Safety Requirements of the EU. This declaration becomes invalid in case of any modifications not agreed upon with us. Furthermore this declaration becomes invalid if the equipment is not used according to this prescription.

Hint: Utilized harmonized standards for this Lashing Point DIN EN 12 100 T1 and T2 as well as EN 1677.

Designation of the equipment:  
Lashing point

Type: LRBS

Manufacturer's sign: 



Before initial usage of the RUD LRBS please read carefully the safety instructions. Make sure that you have understood all subjected matters.

Non-observance can lead to serious personal injuries and material damage and eliminates warranty.

## 1 Safety instructions



### ATTENTION

Wrong positioned or damaged weld-on lashing points as well as improper use can lead to injuries of persons and damage at property. Please check all lashing points carefully before every usage.

- Remove all body parts (fingers, hands, arms, etc.) out of the hazard area (danger of crushing or squeezing) during the lashing process.
- RUD Lashing points LRBS must only be used by instructed and competent persons considering DGUV 109-017, and outside Germany noticing the country specific statutory regulations.
- Do not exceed the LC (Lashing Capacity) indicated on the lashing point.
- Attention: When suspension ring pivots there is a risk of pinching.
- The lashing points must not protrude in rest position over the loading platform level.
- No technical modifications must be made to the LRBS.
- No persons are allowed in the danger zone.
- Damaged or worn LPW must not be used.

## 2 Intended use

RUD Lashing points LRBS must only be used to attach lashing means.

Lashing points must not be used for lifting loads.

RUD Lashing points must only be used in the hereby specified case of operation.

## 3 Assembly- and instruction manual



### HINT

The manufacturer RUD guarantees the overall conformity of the LRBS only after complete and correct implementation of the assembly and welding specifications!

### 3.1 General information

- Capability of temperature usage:  
As of 07/2019: RUD-Lashing points LRBS are suitable for the temperature range from -40°C up to 400°C.

Up to 07/2019: RUD-Lashing points LRBS are suitable for the temperature range from -20°C up to 400°C.

For the use within the following temperature range, the LC (Lashing Capacity) must be reduced by the following factors:

-40°C / -20°C up to 200°C	no reduction
200°C up to 300°C	minus 10 %
300°C up to 400°C	minus 25 %

**Temperatures exceeding 400°C are prohibited!**

In the unloaded state, LRBS lashing points together with the connected component can be stress relieved by heat treating (e.g. welded construction) once. Temperature: < 600°C / 1100° F (one hour maximum).

- RUD-Lashing points LRBS must not be used with aggressive chemicals such as acids, alkaline solutions and their vapours.
- It is recommended, that the places where the lashing points are fixed should be marked with colour.
- The reuse of cut-off LRBS is not permitted.
- RUD Lashing points LRBS are clearly marked at the suspension ring with the permissible Lashing capacity „LC“ in daN.

### 3.2 Hints for the assembly

Basically essential:

- The material construction to which the lashing point will be attached should be of adequate strength to withstand forces during lashing without deformation. The weld-on material must be suitable for welding and the contact areas must be free from dirt, oil, colour, ect. The material of the forged welding block is: S355J2+N (1.0577+N (St52-3))
- The position of the lashing points must be carried out in regard to the lashing means in such a way that unintended movement like turning or flipping of the load will be avoided.
- Consider the die ISO 15818 „Earth-moving machinery - Lifting and tying-down attachment points“.
- Determine number and position of the lashing points at vehicles according to EN 12640 resp. DIN 75410 (for RoRo-transportation acc. to EN 29367), unless the vehicles are not determined due to their design and construction for transporting specific goods with special requirements in regard of load securing.
- Determine the required, permitted Lashing Capacity acc. EN 12195-1 „Load restraining on road vehicles - Safety - Part 1: Calculation of securing forces“, acc. VDI 2700-2 „Securing of loads on road vehicles“ and acc. ISO 15818.



### HINT

The Lashing Points should be arranged (depending on use) as wide as possible to use the full loading area and they should not protrude in steady position.

- Check finally the correct assembly (see chapter 4 Inspection / Repair / Disposal).

### 3.3 Hints for the welding

The welding should only be carried out according to DIN EN ISO 9606-1 or AWS Standards by an authorized and certified welder.

Verification of the used weld-on material must be checked with the supplier of the welding electrodes.



### HINT

- The described welding sequences must be observed compulsive.
- Weld all seams at the same temperature.
- Keep the area of gap for escape of water clear.
- The distance lugs assist in achieving the correct root weld (approx. 3 mm = 0.1 inch). They may not be removed.
- Never weld at the ring!
- Remove any welding mistakes and dirt at the root weld before applying the cover weld seams.
- Avoid end craters.

1 Weld on welding block 1.

Begin at starting point S\* and weld the root and cover weld seams (Pic. 1). Append fillet weld (measurement „a“) acc. Table 1.

Choose type of weld seam and size according to Pic. 6 and Table 1.



Pic. 1: Weld on welding block 1

2 Insert the ring into the welded-on welding block 1.

3 Attach welding block 2 as tight as possible to the ring, in order to still guarantee moveability of ring.

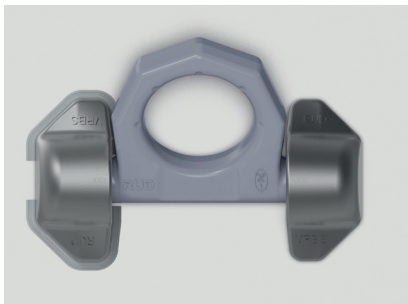

Pic. 2: Align ring and check mobility

4 Tack weld-on block 2 in the area of the distance lugs (only fasten provisionally).

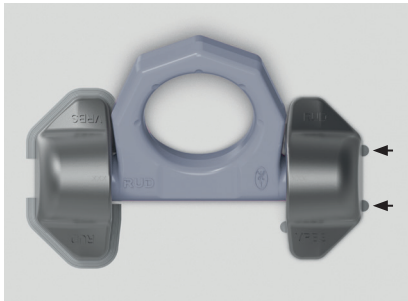

Pic. 3: Attachment in the area of the distance lugs.

5 Check function of the ring. The ring must be able to pivot 180°. If necessary please correct

6 Weld on the welding block 2 according to steps 1 and 2.

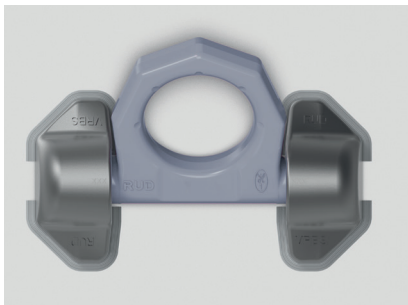

Pic. 4: Weld on welding block 2

7 Please check by a competent person after welding the ongoing usage of the weld-on Lashing point (see chapter 4 Inspection / Repair / Disposal).

### 3.4 User instruction

- Check frequently and before each initial operation the whole lashing point in regard of linger ability as a lashing mean, regarding corrosion, wear, deformation etc. (see chapter 4 Inspection / Repair / Disposal).



#### ATTENTION

Wrong positioned or damaged weld-on lashing points as well as improper use can lead to injuries of persons and damage at property.

Please check all lashing points carefully before every usage.

- Please check carefully the wear indicator markings of the weld-on lashing point (see Pic. 5):

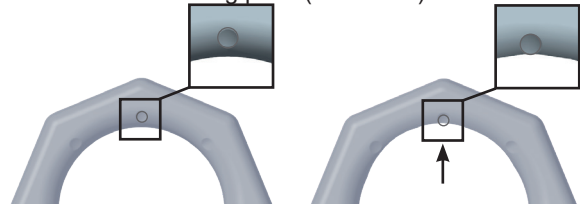

**Usage permitted:**  
no wear marks visible

**Use prohibited:**  
Replacement criteria reached.

Material all the way down to the wear lenses has gone.

Pic. 5: Wear indicators

- Please note that the lashing mean must be free moveable in the LRBS. When lashing means (f.e. lashing chain) are hinged or unhinged, no pinching, shearing or joint spots must occur during the handling.
- Avoid damage of lashing means resulting from sharp edges.
- Lashing points must not be used for lifting loads.

## 4 Inspection / Repair / Disposal

### 4.1 Hints for periodical inspections

The operator must determine and specify the nature and scope of the required tests as well as the periods of repeating tests by means of a risk assessment (see sections 4.2 and 4.3). The continuing suitability of the lashing point must be checked at least 1x year by an expert.

Depending on the usage conditions, f.e. frequent usage, increased wear or corrosion, it might be necessary to check in shorter periods than one year. The inspection has also to be carried out after accidents and special incidents. The operator must specify the test cycles.

### 4.2 Test criteria for the regular visual inspection by the user

- Completeness of the lashing point
- Complete and readable marking of Lashing Capacity as well as manufacturer sign
- Deformation at load bearing components like base body and ring.
- Mechanical damage, like strong notches, especially in areas where tensile stress occurs.

### 4.3 Additional test criteria for the competent person / repair worker

- Reduction of cross-section due to wear >10 %
- Evidence of corrosion (pittings)
- Any other damage
- Further checks may be required, depending on the result of the risk assessment (e.g. testing for cracks in load-bearing parts / at weld seam).

### 4.4 Disposal

Dispose worn out components / attachments or packaging according to the local waste removal requirements.

## 5 Tables / Overview

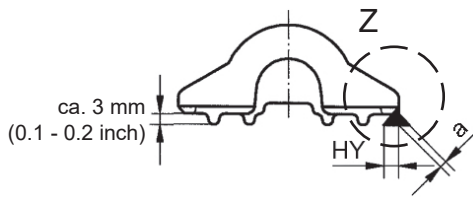

Pic. 6: Seam welding definition

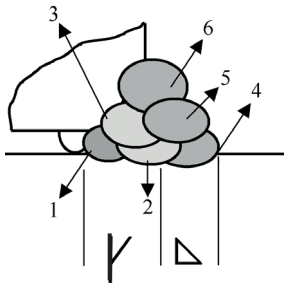

Pic. 7: schematic diagram item „Z“ Welding position PB

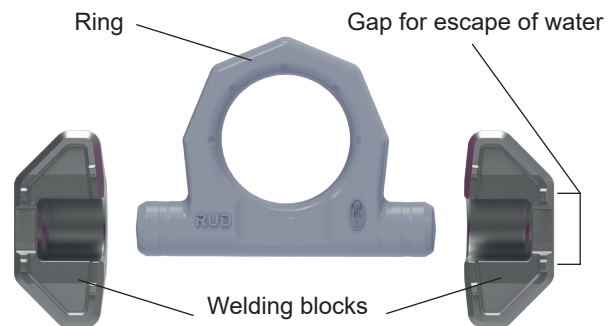

Pic. 8: components LRBS

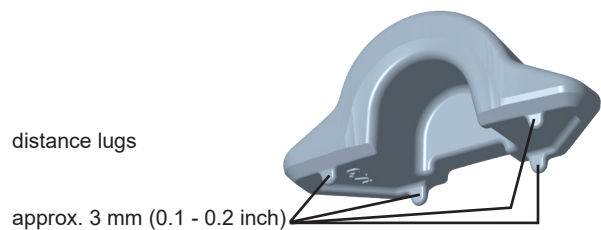

Pic. 9: distance lugs

Type	size	length	volume
LRBS 8,000	HY 4 + a 3 ▽	2 x 130 mm	approx. 4.5 cm <sup>3</sup>
LRBS 13,400	HY 5.5 + a 3 ▽	2 x 170 mm	approx. 9 cm <sup>3</sup>
LRBS 20,000	HY 6 + a 4 ▽	2 x 190 mm	approx. 11 cm <sup>3</sup>
LRBS 32,000	HY 8.5 + a 4 ▽	2 x 250 mm	approx. 26 cm <sup>3</sup>

Table 1: Weld seam (weld-on block)

Europe, USA, Asia, Australia, Africa

Baustähle, niedrig legierte Stähle EN 10025,  
Mild steels, low alloyed steel EN 10025

<b>MIG / MAG (135)</b> <b>Gas shielded wire welding (135)</b>	DIN EN ISO 14341: G4Si1 (G3Si1) z.B. PEGO G4Si1
<b>E-Hand Gleichstrom (111, =)</b> <b>Stick Electrode direct current</b>	DIN EN ISO 2560-A: E 42 6 B 3 2 H10 DIN EN ISO 2560-A: E 38 2 B 1 2 H10 z.B. PEGO B Spezial*/ PEGO BR Spezial*
<b>E-Hand (Wechselstrom 111, ~)</b> <b>Stick Electrode alternating current</b>	DIN EN ISO 2560-A: E 38 2 RB 1 2 DIN EN ISO 2560-A: E 42 0 RC 1 1 z.B. PEGO RC 3 / PEGO RR B 7 Alternativ: DIN EN ISO 3581: E 23 12 2 L R 3 2 z.B. PEGO 309 MoL
<b>WIG (141)</b> <b>TIG Tungsten arc welding</b>	DIN EN ISO 636-A: W 3 Si 1 (W2 Si 1) DIN EN ISO 636-A: W 2 Ni 2 z.B. PEGO WSG 2 / PEGO WSG2Ni2



**HINT**

Please note the corresponding user hint in regard of the welding filler materials and the drying requirements\*.

Table 2: Welding procedure + Welding filler metals

Type	LC [daN]	A [mm]	B [mm]	C [mm]	D [mm]	E [mm]	F [mm]	T [mm]	weight [kg/pc.]	Ref.-No. complete	Ref.-No. weld block	Ref.-No. ring
<b>LRBS (complete)</b>												
LRBS 8,000 daN Oktagon	8,000	62	14	28	48	135	70	65	0.6	7993148	7992004	7910471
LRBS 13,400 daN Oktagon	13,400	88	19	40	60	170	90	84	1.6	7993149	7992005	7910472
LRBS 20,000 daN Oktagon	20,000	100	19.5	46	65	197	98	94	2.6	7993150	7992007	7910473
LRBS 32,000 daN Oktagon	32,000	130	30	57	90	266	134	128	6.9	7993151	7992008	7914462

Table 3: Dimensioning LRBS (complete)

Subject to technical alterations

Type	LC [daN]	A [mm]	B [mm]	C [mm]	D [mm]	E [mm]	F [mm]	G [mm]	K [mm]	N [mm]	T [mm]	weight [kg/pc.]	Ref.-No. ring
<b>LRBS (Ring)</b>													
LRBS 8,000 daN Oktagon	8,000	107	14	69	48	17	18	76	77	19	55	0.4	7910471
LRBS 13,400 daN Oktagon	13,400	134	19	90	60	23	24	99	100	25	71	0.94	7910472
LRBS 20,000 daN Oktagon	20,000	152	19.5	97.5	65	28	29	105	106	30	78	1.4	7910473
LRBS 32,000 daN Oktagon	32,000	204	32	134	90	35	37	146	147	37	103	3.2	7914462

Table 4: Dimensioning LRBS (ring)

Subject to technical alterations

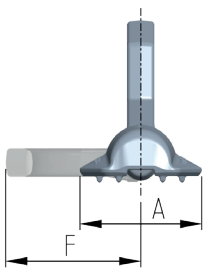

Pic. 10: Dimensioning LRBS (complete)

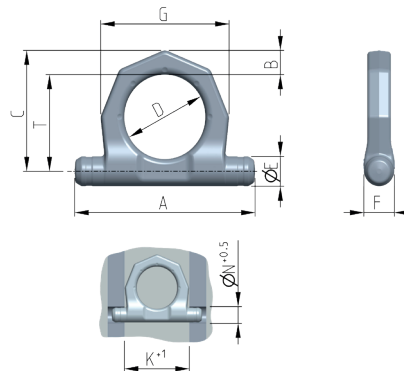
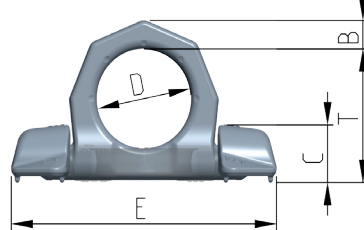

Pic. 11: Dimensioning LRBS (ring)