

Anbauhaken schweißbar
Excavator hook - for welding

> **VABH-W** <

Safety instructions

This safety instruction has to be kept on file for the whole lifetime of the product and forwarded with the product.
Translation of the original safety instruction



RUD Ketten
Rieger & Dietz GmbH u. Co. KG
73432 Aalen
Tel. +49 7361 504-5438
sling@rud.com
www.rud.com

RUD-Art.-Nr.: 8502223-EN -V05 / 07.025

Excavator hook - for welding
VABH-W



EG-Konformitätserklärung

entsprechend der EG-Maschinenrichtlinie 2006/42/EG, Anhang II A und ihren Änderungen

Hersteller: **RUD Ketten**
Rieger & Dietz GmbH u. Co. KG
Friedensinsel
73432 Aalen

Hiermit erklären wir, dass die nachfolgend bezeichnete Maschine aufgrund ihrer Konzipierung und Bauart, sowie in der von uns in Verkehr gebrachten Ausführung, den grundlegenden Sicherheits- und Gesundheitsanforderungen der EG-Maschinenrichtlinie 2006/42/EG sowie den unten aufgeführten harmonisierten und nationalen Normen sowie technischen Spezifikationen entspricht.
Bei einer nicht mit uns abgestimmten Änderung der Maschine verliert diese Erklärung ihre Gültigkeit.

Produktbezeichnung: Anbauhaken
VABH-B / VABH-W / VCGH-G / VCGH-S

Folgende harmonisierten Normen wurden angewandt:

DIN EN 1677-1 : 2009-03 DIN EN ISO 12100 : 2011-03

Folgende nationalen Normen und technische Spezifikationen wurden außerdem angewandt:

DGUV-R 109-017 : 2020-12 DIN 15428 : 1978-08

Für die Zusammenstellung der Konformitätsdokumentation bevollmächtigte Person:
Michael Betzler, RUD Ketten, 73432 Aalen

Aalen, den 15.04.2021

Hermann Kolb, Bereichsleitung MA 
Name, Funktion und Unterschrift Verantwortlicher



EC-Declaration of conformity

According to the EC-Machinery Directive 2006/42/EC, annex II A and amendments

Manufacturer: **RUD Ketten**
Rieger & Dietz GmbH u. Co. KG
Friedensinsel
73432 Aalen

We hereby declare that the equipment sold by us because of its design and construction, as mentioned below, corresponds to the appropriate, basic requirements of safety and health of the corresponding EC-Machinery Directive 2006/42/EC as well as to the below mentioned harmonized and national norms as well as technical specifications.
In case of any modification of the equipment, not being agreed upon with us, this declaration becomes invalid.

Product name: Bolt on / Weld on hook
VABH-B / VABH-W / VCGH-G / VCGH-S

The following harmonized norms were applied:

DIN EN 1677-1 : 2009-03 DIN EN ISO 12100 : 2011-03

The following national norms and technical specifications were applied:

DGUV-R 109-017 : 2020-12 DIN 15428 : 1978-08

Authorized person for the configuration of the declaration documents:
Michael Betzler, RUD Ketten, 73432 Aalen

Aalen, den 15.04.2021

Hermann Kolb, Bereichsleitung MA 
Name, function and signature of the responsible person



Before initial usage of the RUD VABH-W, please read carefully the safety instructions. Make sure that you have understood all subjected matters.

Non-observance can lead to serious personal injuries and material damage and eliminates warranty.

1 Safety instructions



ATTENTION

Wrong positioned or damaged weld-on lifting points as well as improper use can lead to injuries of persons and damage at property, when load falls down.

Please check all lifting points carefully before every usage.

- Remove all body parts (fingers, hands, arms, etc.) out of the hazard area (danger of crushing or squeezing) during the lifting process.
- RUD-Lifting points VABH-W must only be used by instructed and competent persons considering DGUV 109-017, and outside Germany noticing the country specific statutory regulations.
- Do not exceed the working load limit (WLL) indicated on the lifting point.
- No technical alterations must be implemented on the VABH-W.
- No people may stay in the danger zone.
- Jerky lifting (strong impacts) should be prevented.
- Always ensure a stable position of the load when lifting. Swinging must be prevented.
- Damaged or worn VABH-W must never be utilised.

2 Intended use

RUD Lifting points VABH-W must only be used for the assembly at the load or at lifting means.

They are designed and intended to attach lifting means.

RUD Lifting points can also be used as lashing points to attach lashing means.

RUD-lifting points must only be used in the hereby specified case of operation.

3 Assembly- and instruction manual



HINT

The manufacturer RUD guarantees the overall conformity of the VABH-W only after complete and correct implementation of the assembly and welding specifications!

3.1 General information

- Capability of temperature usage:
RUD-Lifting points VABH-W are suitable for the temperature range from -40°C up to 400°C.
For the use within the following temperature range, the working load limit (WLL) must be reduced by the following factors:
-40°C up to 200°C no reduction
200°C up to 300°C minus 10 %
300°C up to 400°C minus 25 %
Temperatures exceeding 400°C are prohibited!

- RUD lifting points VABH-W must not be used with aggressive chemicals such as acids, alkaline solutions and their vapours.
- The reuse of cut-off VABH-Ws is not permitted.
- Please mark mounting position of lifting point with a coloured contrast paint for better visibility.

3.2 Hints for the assembly

Basically essential:

- The material construction to which the lifting point will be attached should be of adequate strength to withstand forces during lifting without deformation. The weld-on material must be suitable for welding and the contact areas must be free from dirt, oil, colour, ect.
The material of the forged welding block is: 1.6541 (23MnNiCrMo52)
- The position of the lifting points must be carried out in such a way that unintended movement like turning or flipping will be avoided.
 - **For single leg lifts**, the lifting point should be vertically above the centre of gravity of the load
 - **For two leg lifts**, the lifting points must be equidistant to/or above the centre of gravity of the load.
 - **For three and four leg lifts**, the lifting points should be arranged symmetrical around the centre of gravity, in the same plane if possible.

- Load symmetry:
Determine the necessary WLL of each lifting point for a symmetrical load by using the following physical calculation formula:

$$W_{LL} = \frac{G}{n \times \cos \beta}$$

W_{LL} = necessary WLL of lifting point / single strand (kg)
 G = weight of load (kg)
 n = number of load bearing strands
 β = inclination angle of single strand

Number of load bearing strands:

	Symmetric
two leg	2
three / four leg	3

Table 1: Load bearing strands (compare to Table 2)



HINT

At unsymmetrical loads, even if several lifting points are used, the WLL of a single lifting point must be at least equal to the load weight or ask the manufacturer.

- Check finally the correct assembly (see chapter 4 *Inspection / Repair / Disposal*).

3.3 Hints for the welding

The welding should only be carried out according to DIN EN ISO 9606-1 or AWS Standards by an authorized and certified welder.

Verification of the used weld-on material must be checked with the supplier of the welding electrodes



HINT

- *Weld all seams at the same temperature*

- 1 Fasten provisionally, resp. start welding in the middle of the plate.
- 2 Before the closure weld is carried out, make sure that the bottom and all interlayers are cleaned carefully. Remove all visible flaw spots of the root and at the interlayers.
- 3 Weld fillet weld continuous at the base plate of the lifting point.
- 4 Please check by a competent person after welding the ongoing usage of the weld-on lifting point (see chapter 4 *Inspection / Repair / Disposal*).



HINT

By the position of the weld-seam (HY-weld circumferential) the following requirements will be observed: DIN 18800 steel constructions requires: at outdoor buildings or when strong corrosion must be expected weld seams must be carried out as continuous fillet weld seams.

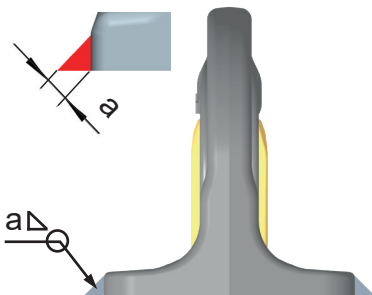

Pic. 1: Weld seam

3.4 User instruction

- Check frequently and before each initial operation the whole lifting point in regard of linger ability as a lifting mean, regarding corrosion, wear, deformation etc. (see chapter 4 *Inspection / Repair / Disposal*).



ATTENTION

Wrong positioned or damaged weld-on lifting points as well as improper use can lead to injuries of persons and damage at property, when load falls down.

Please check all lifting points carefully before every usage.

- RUD components are designed according to DIN EN 818 and DIN EN 1677 for a dynamic load of 20,000 load cycles.
 - Keep in mind that several load cycles can occur with a lifting procedure
 - Keep in mind that, due to the high dynamic stress with high numbers of load cycles, that there is a danger that the product will be damaged.
 - The BG/DGUV recommends: For higher dynamic loading with a high number of load cycles (continuous operation), the working load stress must be reduced according to the driving mechanism group 1Bm (M3 in accordance with DIN EN 818-7). Use a lifting point with a higher working load limit.
- Please check carefully the wear indicator markings of the weld-on lifting point (see Pic. 2):

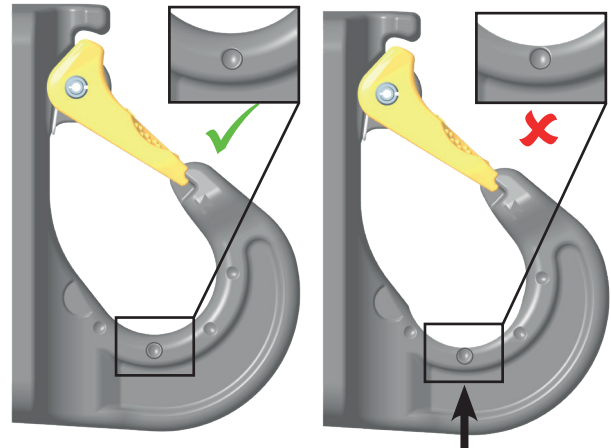

Usage permitted:
no wear marks visible

Use prohibited:
Replacement criteria reached. Material all the way down to the wear lenses has gone

Pic. 2: Wear indicators

- Please note that the lifting mean must be free moveable in the VABH-W. When lifting means (f.e. lifting chain) are hinged or unhinged, no pinching, shearing or joint spots must occur during the handling.
- Avoid damage of lifting means resulting from sharp edges.
- If RUD VABH-W lifting points are used solely for lashing, the value of the working load limit can be doubled. $LC = \text{permissible lashing force} = 2 \times \text{working load limit (WLL)}$.



HINT

If the VABH-W is/was used as a lashing point, with a force higher than the WLL, it must not be used as a lifting point afterwards.

If the VABH-W is/was used as a lashing point, up to the WLL only, it can still be used afterwards as a lifting point.

4 Inspection / Repair / Disposal

4.1 Hints for periodical inspections

The operator must determine and specify the nature and scope of the required tests as well as the periods of repeating tests by means of a risk assessment (see sections 4.2 and 4.3).

The continuing suitability of the anchor point must be checked at least 1x year by an expert.

Depending on the usage conditions, f.e. frequent usage, increased wear or corrosion, it might be necessary to check in shorter periods than one year. The inspection has also to be carried out after accidents and special incidents.

4.2 Test criteria for the regular visual inspection by the user

- Completeness of the lifting point
- Complete, readable WLL statements as well as manufacturer sign.
- Deformation at load bearing components like base body
- Mechanical damage, like strong notches, especially in areas where tensile stress occurs.
- Damage maximum until the forged-in patented wear lenses are reached (*Pic. 2*).

4.3 Additional test criteria for the competent person / repair worker

- Reduction of cross-section due to wear >10 % (see Wear indicators)
- Increase in jaw width due to overload > 10 % (see marking points for checking dimension of jaw width).
- Evidence of corrosion (pittings)
- Any other damage at weld seam
- Further checks may be required, depending on the result of the risk assessment (e.g. testing for cracks in load-bearing parts / at weld seam).

4.4 Disposal

Dispose worn out components / attachments or packaging according to the local waste removal requirements.









Method of lift										
Number of legs	1	1	2	2	2	2	2	3 & 4	3 & 4	3 & 4
Angle of inclination β	0°	90°	0°	90°	0-45°	45-60°	un-symm.	0-45°	45-60°	un-symm.
Factor	1	1	2	2	1.4	1	1	2.1	1.5	1
Type WLL in metric tons . bolted and adjusted to the direction of pull										
VABH-W 1.5 t	1.5	1.5	3	3	2.1	1.5	1.5	3.15	2.25	1.5
VABH-W 2.5 t	2.5	2.5	5	5	3.5	2.5	2.5	5.25	3.75	2.5
VABH-W 4 t	4	4	8	8	5.6	4	4	8.4	6	4
VABH-W 6.7 t	6.7	6.7	13.4	13.4	9.5	6.7	6.7	14.1	10	6.7
Type WLL in lbs. bolted and adjusted to the direction of pull										
VABH-W 1.5 t	3300	3300	6600	6600	4660	3300	3300	7000	4950	3300
VABH-W 2.5 t	5500	5500	11000	11000	7700	5500	5500	11660	8250	5500
VABH-W 4 t	8820	8840	17600	17600	12470	8820	8820	18710	13230	8820
VABH-W 6.7 t	14770	14770	29540	29540	20880	14770	14770	31330	22150	14770

Table 2: WLL overview

Europe, USA, Asia, Australia, Africa

Baustähle, niedrig legierte Stähle
EN 10025 | Mild steels, low alloyed steel

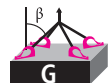
MIG / MAG (135) Gas shielded wire welding (135)	DIN EN ISO 14341: G4Si1 (G3Si1) Z.B. PEGO G4Si1
E-Hand Gleichstrom (111, =) Stick Electrode direct current	DIN EN ISO 2560-A: E 42 6 B 3 2 H10 DIN EN ISO 2560-A: E 38 2 B 1 2 H10 z.B. PEGO B Spezial*/ PEGO BR Spezial*
E-Hand (Wechselstrom 111, ~) Stick Electrode alternating current	DIN EN ISO 2560-A: E 38 2 RB 1 2 DIN EN ISO 2560-A: E 42 0 RC 1 1 z.B. PEGO RC 3 / PEGO RR B 7 Alternativ: DIN EN ISO 3581: E 23 12 2 L R 3 2 z.B. PEGO 309 MoL
WIG (141) TIG Tungsten arc welding	DIN EN ISO 636-A: W 3 Si 1 (W2 Si 1) DIN EN ISO 636-A: W 2 Ni 2 z.B. PEGO WSG 2 / PEGO WSG2Ni2

Table 3: Welding procedure + Welding filler metals



HINT

Please note the corresponding user hint in regard of the welding filler materials and the drying requirements*.

Type	Tragf. / WLL [t]	A [mm]	B [mm]	C [mm]	D [mm]	E [mm]	F [mm]	I [mm]	T [mm]	weight [kg/pc.]	packing unit	Ref.no.
VABH-W 1.5 t	1.5	7.5	76	115	111	70	21	38	26	0.85	4	7991208
VABH-W 2.5 t	2.5	8.5	98	148	143	85	28	49	33	1.67	4	7991209
VABH-W 4 t	4	11	119	168	164	104	35	59	40	2.95	2	7991210
VABH-W 6.7 t	6.7	13	147	205	200	120	40	70	51	5.19	1	8502239

Table 4: Dimensioning

Subject to technical alterations

Type	size fillet weld	length	volume
VABH-W 1.5 t	a = 4	322 mm	5.2 cm ³
VABH-W 2.5 t	a = 5	424 mm	10.6 cm ³
VABH-W 4 t	a = 6	481 mm	17.3 cm ³
VABH-W 6.7 t	a = 6	574 mm	20.6 cm ³

Table 5: Weld seam

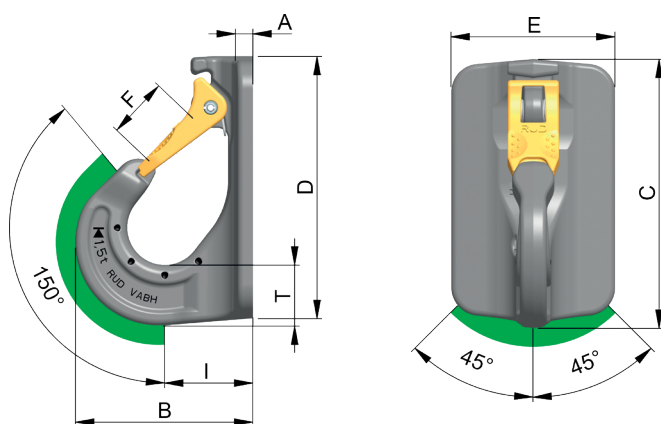

Pic. 3: Dimensioning / allowed load directions