

VIP Bale hook >VBMHWA<

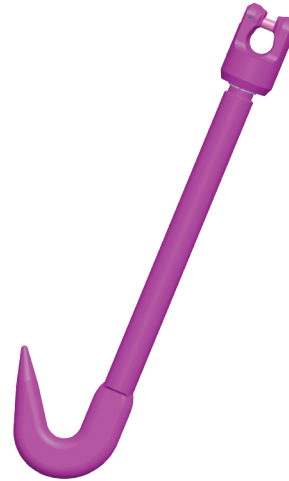

Assembly instruction

This Assembly instruction has to be kept on file for the whole lifetime of the product and forwarded with the product
ORIGINAL ASSEMBLY INSTRUCTION
 This assembly instruction is valid in addition to the safety instructions for VIP Sling chains (VIP-No. 7101649).



RUD Ketten
Rieger & Dietz GmbH u. Co. KG
 73428 Aalen
 Tel. +49 7361 504-1370
 Fax +49 7361 504-1460
 sling@rud.com
 www.rud.com

RUD-Art.-Nr.: 7913065-EN V03 / 03.023

VIP Bale hook VBMHWA



Simple inspection, administration and documentation of work equipment and components which must be inspected regularly.

EG-Einbauerklärung	
entsprechend der EG-Maschinenrichtlinie 2006/42/EG, Anhang II B und ihren Änderungen	
Hersteller:	RUD Ketten Rieger & Dietz GmbH u. Co. KG Friedensinsel 73432 Aalen
Hiermit erklären wir, dass die nachfolgend bezeichnete unvollständige Maschine den grundlegenden Anforderungen der Maschinenrichtlinie 2006/42/EG (Anhang 1) entspricht. Die nachfolgend bezeichnete unvollständige Maschine darf, in der gelieferten Ausführung erst dann in Betrieb genommen werden, wenn festgestellt wurde, dass die Maschine, in die diese unvollständige Maschine eingebaut werden soll, den Anforderungen der EG-Maschinenrichtlinie 2006/42/EG entspricht.	
Produktbezeichnung:	<u>Baustahlmattenhaken</u> <u>VBMHWA / VBMH</u>
Folgende harmonisierten Normen wurden angewandt:	<u>DIN EN 1677-1 : 2009-03</u> <u>DIN EN ISO 12100 : 2011-03</u> _____ _____ _____
Folgende nationalen Normen und technische Spezifikationen wurden außerdem angewandt:	<u>DGUV-R 109-017 : 2020-12</u> _____ _____ _____
Die speziellen Unterlagen zur unvollständigen Maschine nach Anhang VII Teil B wurden erstellt und werden auf begründetes Verlangen in geeigneter Form übermittelt.	
Für die Zusammenstellung der Konformitätsdokumentation bevollmächtigte Person: Michael Betzler, RUD Ketten, 73432 Aalen	
Aalen, den 01.06.2022	Hermann Kolb, Bereichsleitung MA
Name, Funktion und Unterschrift Verantwortlicher	

EC-Mounting declaration	
According to the EC-Machinery Directive 2006/42/EC, annex II B and amendments	
Manufacturer:	RUD Ketten Rieger & Dietz GmbH u. Co. KG Friedensinsel 73432 Aalen
We hereby declare that the following incomplete machines correspond to the basic requirements of the Machinery Directive 2006/42/EC (annex 1). The following incomplete machine, in the delivered machine, may only be put into operation when the machine in which the incomplete machine shall be assembled, has been tested according to the requirements of the EC-Machinery Directive 2006/42/EC.	
Product name:	<u>Bale hook</u> <u>VBMHWA / VBMH</u>
The following harmonized norms were applied:	<u>DIN EN 1677-1 : 2009-03</u> <u>DIN EN ISO 12100 : 2011-03</u> _____ _____ _____
The following national norms and technical specifications were applied:	<u>DGUV-R 109-017 : 2020-12</u> _____ _____ _____
The special documents about the incomplete machine according to annex VII part B have been created and can be handed over in a suitable form on request.	
Authorized person for the configuration of the declaration documents: Michael Betzler, RUD Ketten, 73432 Aalen	
Aalen, den 01.06.2022	Hermann Kolb, Bereichsleitung MA
Name, function and signature of the responsible person	



Please read assembly instruction carefully before initial operation of VIP Bale hook. Make sure to understand all subjected matters.

Disregard of the assembly manual can lead to serious physical injury and property damage and eliminates warranty.

In doubt or in misconception please note that the German version of this document is decisive.

1 Safety instructions



ATTENTION

Wrong assembled or damaged lifting and lashing means as well as improper use can lead to injuries of persons and damage of objects when load drops.

Please inspect all lifting points before each use.



ATTENTION

When using Bale hooks increased caution must become affect, resp. before the usage a risk assessment according to Betr.SichV §3 must be carried out.

VIP Bale hooks must only be used when unintentional unhinge is impossible.



ATTENTION

VIP Bale hooks must not be used at construction sites.

Detention under a floating load is forbidden. No people may stay in the danger zone.

- Remove all body parts (fingers, hands, arms, etc.) out of the hazard area (danger of crushing or squeezing) during the lifting process.
- VIP Bale hook must only be used by instructed and competent persons considering DGUV-rules 109-017 and outside Germany noticing the country specific statutory regulations.
- Use the VIP Bale hook in the 4-strand VIP sling, with equal load distribution of the reinforcement mesh packages.
- No technical alterations must be implemented on the VIP Bale hook.
- Jerky lifting (strong impacts) should be prevented.
- Always ensure a stable position of the load when lifting. Swinging must be prevented
- Please be also aware of extreme circumstances or shock loads when selecting the used VIP Bale hook and the components.
- Damaged or worn VIP Bale hooks must never be utilised.
- Only the determined RUD round steel chain of the correct nominal size and quality grade must be used with the VIP Bale hook.

2 Intended use

The described VIP Bale hooks must only be used for lifting and transporting of construction steel mesh, if unintentional unhinge is prohibited.

This is not valid, if an unhinge without a rigging person is necessary due to special risks of accidents.

The VIP Bale hook must not be hooked into the cording of the steel mesh package.

Before the usage, a risk assessment according to Betr.SichV §3 should be carried out.

VIP Bale hooks are not suitable for the transport overhead of people.

VIP Bale hooks must only be used in the hereby described operation purpose.

3 Assembly- and instruction manual

3.1 General information

• Capability of temperature usage of VIP Bale hook (VBMHWA):

When using the VIP Bale hook at temperatures beyond 200°C the permissible WLL of the VIP Bale hook has to be reduced:

- -40°C up to 200°C no reduction
- 200°C up to 300°C minus 10 %
- 300°C up to 380°C minus 40 %

- Temperatures exceeding 380°C are prohibited!

- The special pink-powder coating of the components changed permanently the colouring, if the use was in high temperatures. The colour deep black signals a use over 380°C.



HINT

After use over 380°C (chain is colours deep black) is a continuing use not allowed.

The quality of the chain is no longer guaranteed.

- VIP Bale hooks must not be used with aggressive chemicals such as acids, alkaline solutions and their vapours.
- The WLL of components are depending on the following variables:
 - Quality grade of component (Abb./Pic. 1)
 - Nominal size of component
 - in the present case

The permissible WLL should be taken out of the according VIP user's instruction (or alternatively from the RUD website www.rud.com).

3.2 Hints for the assembly

Please observe correct assignment of chain and component when assembling the VIP Bale hook. The quality grade/nominal size or the component can be identified by the stamping at component/bolt/chain resp. by the colour.



HINT

Observe in any case the quality grade assignment at the components.
For the VIP Bale hook (VBMHWA), install only clevis pin with H1-10 stamping.
Mixing of system components from different quality grades/nominal sizes is not allowed.



Abb./Pic. 1: **Quality grade 100** | VIP-Chain | Stamping H1-10 | Round pin H1-10

Basically essential:

- For VIP Bale hooks use only the round VIP G-pin (Abb./Pic. 1)
- The G-pin must be assembled captive with the slotted pin and with the step hole in the component (Abb./Pic. 2).

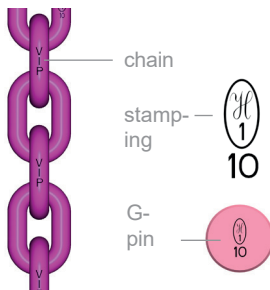

Abb./Pic. 2: Assembly of connecting pin

- RUD G-pins are fool-proof.

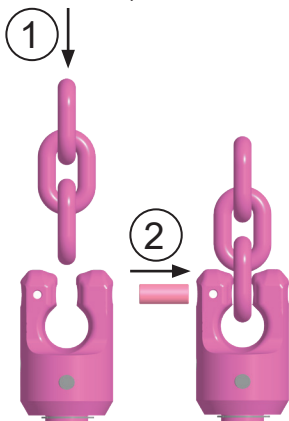

Abb./Pic. 3: G-pin assembly with slotted pin and step hole (right). G-pin of the next smaller size falls out.

- Assemble clamping pin for the securing of the G-Pin in such a way at the clevis that the opening / slot of dowel pin can be seen from outside.

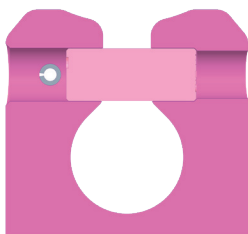

Abb./Pic. 4: Assembly clamping pin

- Use only original RUD spare parts.

Size	clevis pin	clamping pins	Ref.No.
VIP 8	10 pieces	10 pieces	7985640
VIP 10	10 pieces	10 pieces	7985641

Tabelle/Table 1: Content per RUD-spare-parts-set clevis pin / dowel pin

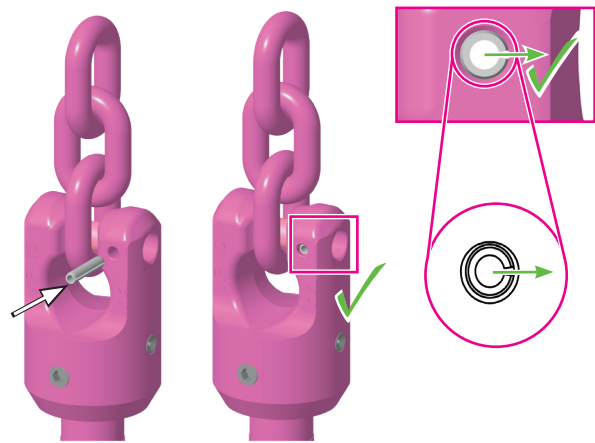
- Finally check after the installation the ongoing ability by a competent person (see chapter 4 Inspection / repair / disposal).

3.3 General user information

- Check before each usage of the VIP Bale hooks that the securing of the G-pin is in correct position.
- Make sure that the load force happens in the straight leg without being twisted, fold-over or kinked.
- Control frequently and before each operation the total lifting/lashing mean in regard of ongoing ability, strong corrosion, wear, deformation etc. (see chapter 4 Inspection / repair / disposal).



WARNING

Wrong assembled or damaged lifting- and lashing means as well as improper usage can lead to physical injury and damage of property when load falls.
Inspect lifting and lashing means before each use carefully!

- RUD components have been designed as per DIN EN 818 and DIN EN 1677 for a dynamic load of 20,000 load cycles.
 - Observe and be aware that multiple load cycles can occur during a lifting operation.
 - Observe the risk of product damage caused by high dynamical influences at high load cycle numbers.
 - The BG/DGUV recommends: For higher dynamic loading with a high number of load cycles (continuous operation), the working load stress must be reduced according to the driving mechanism group 1Bm (M3 in accordance with DIN EN 818-7). Use a lifting mean with a higher working load limit.

- Leave hazardous area when possible.
- Watch always attached loads.
- For all lifting/lashing means observe the RUD sling chain Safety instructions for RUD lifting means resp. the relevant WLL (VIP quality grade 100).

3.4 Important hint for the usage



ATTENTION

Only VIP Bale hooks may be attached into the matching steel meshes mats. Hanging into components, eyelets etc. is not permitted.

- Always hang the VIP Bale hooks with the hook opening facing outwards (Abb./Pic. 5 / Abb./Pic. 7).
- Always hang the VIP Bale hook in the lowest layer of the steel mesh packages and not in the lacing of the package.

3.4.1 Permissible application

The following applications for the VIP Bale hook are permissible:



Abb./Pic. 5: 4-strand application



Abb./Pic. 6: Top view - 4-strand application

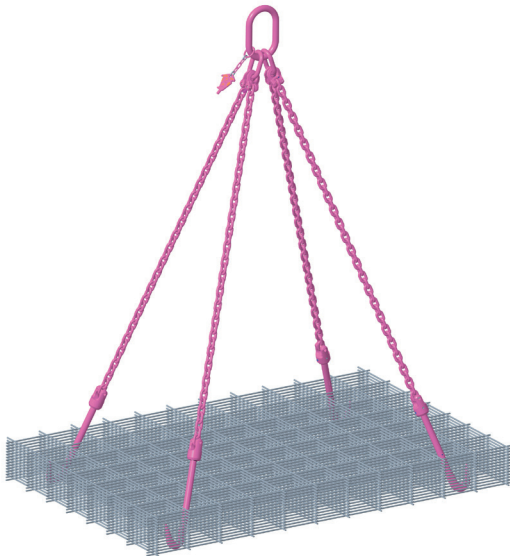

Abb./Pic. 7: 4-strand application - Hook opening directed outward

3.4.2 Prohibited application

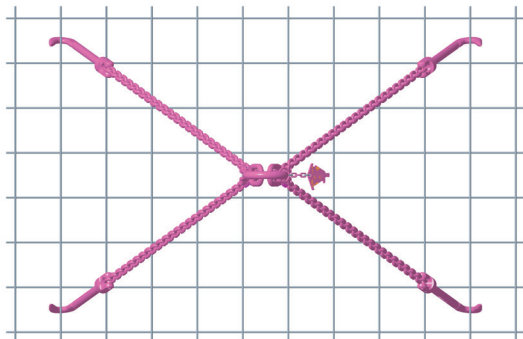
The following applications for the VIP Bale hooks are prohibited:

- Incorrect loading or unintentional unscrewing or unhooking of the VIP Bale hook is possible.

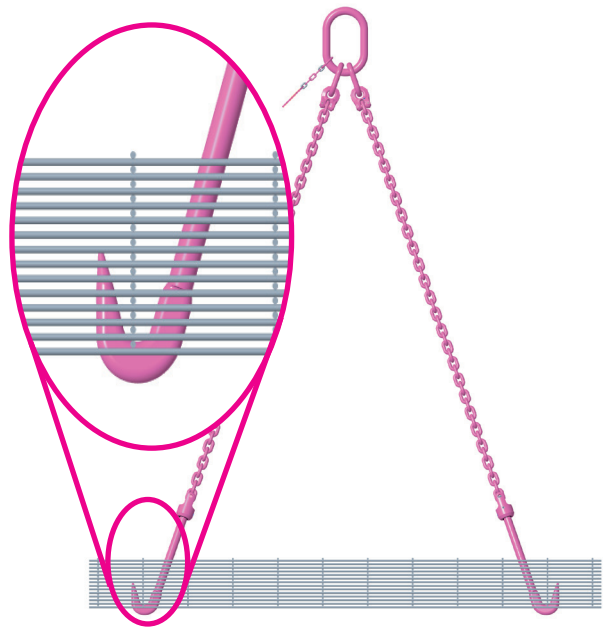

Abb./Pic. 8: Misapplication

3.4.3 Setting down the load

Before setting down the load, make sure that the ground is sufficiently prepared to stabilize the load and properly remove the VIP Bale hook properly.

4 Inspection / repair / disposal

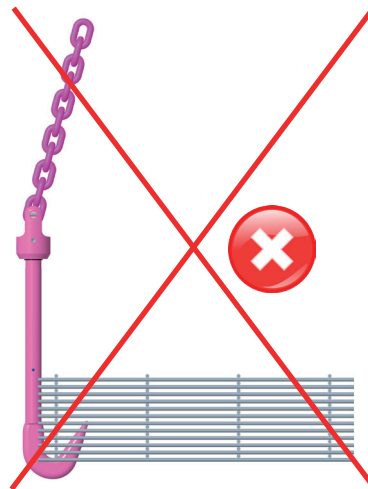
4.1 Hints for the regularly inspection

The operator must determine and specify the nature and scope of the required tests as well as the periods of repeating tests by means of a risk assessment (see sections 4.2 and 4.3). The continuing suitability of the lifting mean must be checked at least 1x year by an expert.

Depending on the usage conditions, f.e. frequent usage, increased wear or corrosion, it might be necessary to check in shorter periods than one year. The inspection has also to be carried out after accidents and special incidents.

The operator must specify the test cycles.

4.2 Test criteria for the regular visual inspection by the user

- Completeness of the VIP Bale hook
- Complete and readable size and manufacturer sign
- Deformation or widening of the component.
- Mechanical damage like strong notches, especially in areas where tensile stress occurs.
- Cracks or other defects especially notches at the bearing point of the hook.

Wear limit gap dimension

The following gap dimension between the underside of the swivelling body and the square retaining ring must not exceed the following value:

- VBMHWA-8: $S_{max} = 1.3 \text{ mm}$
- VBMHWA-10: $S_{max} = 1.5 \text{ mm}$



HINT

Before measuring, push the square circlip ring all the way down and check the distance with a gauge.



Abb. 9: Wear limit gap dimension

4.3 Additional test criteria for the competent person / repair worker

- Reduction of cross-section due to wear > 10 %
- Strong corrosion
- further checks may be required, depending on the result of the risk assessment (e.g. testing for cracks in load-bearing parts).

4.4 Hints for inspection / repairing

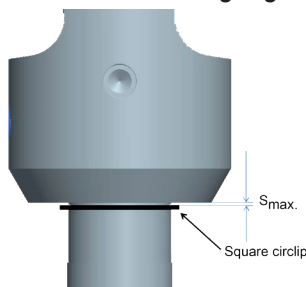
- Repair work may only be executed by qualified specialists who can verify the necessary skills and training.
- Please keep test protocols and records of the inspection at least until the next inspection takes place.
- Only RUD original spare parts must be used and all repairing and overhauling operations must be documented in the chain card file (of the complete lifting mean) or use the AYE-D.NET-System.
- VIP Bale hooks are equipped with a RUD ID-Point® and can be identified by the unique 16 character number. This code can be captured and transferred with the RUD ID-EASY-CHECK® readers into the AYE-D.NET. This application supports you with the administration and documentation of your components.
- More information can be found either on the internet or through your local RUD contact person.

4.5 Disposal

Dispose worn out components / attachments or packaging according to the local waste removal requirements.



Abb./Pic. 10: Dimensioning

	Denomination	Chain	WLL [t]	A [mm]	B [mm]	C [mm]	D [mm]	E [mm]	F [mm]	R [mm]	T [mm]	weight [kg/pc.]	Ref.-No.
VIP	VBMHWA-8	VIP-8	2.5	35	18	61	26.5	77	108	15	389	2.4	7991478
	VBMHWA-10	VIP-10	4	35	18	61	26.5	73	108	15	394	2.8	7989017

Tabelle/Table 2: Dimension chart

Technical alterations subject to change

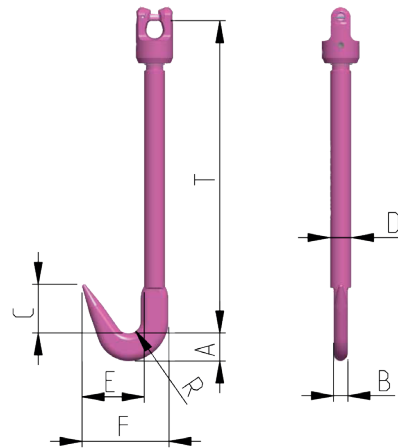

HINT

The permissible WLL should be taken out of the according VIP user's instruction (or alternatively from the RUD website www.rud.com).